

1477 E. Michigan Ave.
Battle Creek, MI
49014-8950

Hours: 7:30-4:45pm est.
Monday-Friday

THE FERREE PRESS



Ph: 800-253-2261 or
269-965-0511
Fax: 269-965-7719

For Orders & Acct-
E: ferreestools@aol.com
For Tool & Repair data-
E: repairtips@aol.com

January 2008



Pg. 1

NEW YAMAHA SAX PAD ASSORTMENTS

These new pad assortments containing either 264 pads or 504 pads are for Yamaha saxes built "After 1988". The assortments are made up of: A minimum, one dozen of every size required and two dozen of 2 more used sizes in the 264 pad assortment -OR- A minimum of one dozen of each size required and even more dozens, or more, of each of the most used sizes in the 504 pad assortment. *This keeps your costs at a minimum;* you need only replenish what you use most.

All pads used in these Yamaha Specific assortments are Ferree's B52M's. They are .160" thick, metrically sized and are similar in appearance to the proprietary Yamaha pads.

The odd number of pads in these assortments was dictated by the sizes required and frequency of use. We are sure this will be just a start for many.

From those necessary purchases, you can figure your approximate normal usage of a size, for the future.

These NEW assortments cover only the following models of Yamaha Soprano, Alto and Tenor saxophones produced after 1988 according to them. **YSS62 Soprano, YAS23 Alto, YAS52/62 Pro Alto, YTS23 Tenor and YTS52/62 Pro Tenor.** You will have to add more quantity of a size as you use these but, these assortments will get you started right and you won't have any left over that you won't eventually use.

If you are working on any pre-1988 instruments, such as the YAS21 Alto, YAS61 Pro Alto, YTS21 Tenor and YTS61 Pro Tenor, you will have to add a few more sizes. -OR- If you are working on the Baritone saxophone, YBS52/62, you will have to add some bigger sizes.



In fact, we have now done that for you. For your convenience two addendum assortments are now optional for these purposes. These two new groupings contain only the additional pads you will need to be able to do the additional instruments involved.

B52MY264	Sm. Asst. for Yamaha Saxes	\$433.20
B52MY504	Lg. Asst. for Yamaha Saxes	\$820.40
B52MYOLD	Add'l Pads for Pre-'88s	\$141.10
B52MYBAR	Add'l Pads for Baritones	\$182.10

FEBRUARY 2008 FREE REPAIR DIRECTIVES

If there is enough interest shown THERE WILL BE a directive on soldering, both soft soldering (like brace repairs and tuning slides, etc.) AND silver soldering (as in key repair and modification) on **February 2nd 2008.**

FEBRUARY 9TH~Dent Machine Directive ***NEW***

*Brass & Saxophone usages of the Z60

*Accessories

*Z61,Z61E,Z60-50, etc..

FEBRUARY 16TH~Woodwind Directive

FEBRUARY 23RD~Brasswind Directive

There is NO CHARGE for these sessions, which run from 9AM until 5PM. There is a \$50.00 deposit required; returnable at the door! Limited to 12 persons.

**Location: Ferree's Tools, Inc. Battle Creek, MI
CALL TODAY TO MAKE A RESERVATION!!!**

1477 E. Michigan Ave.
Battle Creek, MI
49014-8950

Hours: 7:30-4:45pm est.
Monday-Friday

THE FERREE PRESS



Ph: 800-253-2261 or
269-965-0511
Fax: 269-965-7719

For Orders & Acct-
E: ferreestools@aol.com
For Tool & Repair data-
E: repairtips@aol.com

January 2008

©

Pg. 2

NEW ERV STRING REPAIR FOR BAND INSTRUMENT REPAIRMEN

Here it is! A violin repair manual written especially for Band Instrument Repairmen by a Band Instrument Repairman who is also well schooled as a Luthier. Richard Ervin, who trained with roots going back to the Mittenwald school in Germany, makes string repair understandable and easy to perform.



ERV String Repair Book \$29.95

N14 MOUTHPIPE RECEIVER FORMING MANDRELS

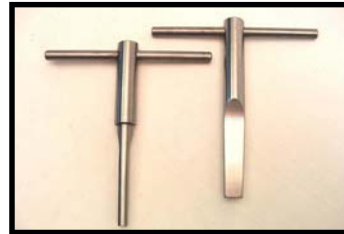

When installing a new French horn mouthpiece or a new trombone venturi tube, these custom steel forming dies provide the proper taper to receive the mouthpiece inside the ferrule or cork barrel.

N14A For French Horn Mouthpipe \$29.50
N14B For Trombone Mouthpipe \$29.50
NEW N14C Bass Trombone Mouthpipe
Mandrel \$29.50

NEW P61 BACK ROTOR BEARING PLATE EXPANDER



A super tool for tightening loose bearing plates in worn rotor valves.

Quickly tightens bearing plates by expanding their diameter by "swedging" them while they spin in this handy fixture that is mounted in your lathe or even your bench motor. Roller makes easy work of this old problem.

P61 Back Rotor Bearing Plate Expander \$77.50

NEW E5 STAINLESS STEEL SPRING REMOVING PLIER



This plier will remove whole springs without breaking them when overhauling a reed instrument. Designed with tremendous leverage for better gripping power. Now, stainless steel, box-joint. 5" (127mm) long.

E5 Spring Removing Plier \$39.50

NEW ONLINE PRICE LIST

Our price list is now online and updated regularly. Just go to www.ferreestools.com and click on Price Lists.



1477 E. Michigan Ave.
Battle Creek, MI
49014-8950

Hours: 7:30-4:45pm est.
Monday-Friday

THE FERREE PRESS



Ph: 800-253-2261 or
269-965-0511
Fax: 269-965-7719

For Orders & Acct-
E: ferreestools@aol.com
For Tool & Repair data-
E: repairtips@aol.com

January 2008

©

Pg. 3

COMING SOON P88 TUBING TRUE TOOL



These NEW "Tubing True Tool" mandrels allow the most precision and accurate way to round and straighten brass band instrument

tubing, including trombone slide rail tubes.

These new precision ground mandrels allow about a 3 times more precise fit than even our regular mandrels; both foreign and domestic.

The new 11" length brings this proven idea into the 21st century, so that in conjunction with your N87A trombone pliers you will have the perfect meld of both accuracy and speed. 34 sizes available.

The N87A requires approximately 5.5" of work space for best results. The NEW P88 provides 11" for a 100% safety factor. The P88 also has incorporated a delrin "Safety Stop" to help prevent "over run", which is used on our P53 with great success for several years. Comes with instructions.

P88L Set of 2 trombone handles (2 diameters)

P88S Set of 2 regular tube handles (2 diameters)

P88M Indv. Mandrels by size from .440" to .605" by .005" graduations.

D6 CONICAL BENCH PEGS

Properly tapered to hold all clarinet joints between the bench and body. Braces any sax gooseneck, while sanding the cork. Machined of steel, chrome plated, lasts indefinitely, unlike the old fashioned wood plug. Easily installed and removed from small 3/8" (9.5mm) hole in the bench.



D6 Bench Peg-Traditional \$8.50



This combination reverse cone works with bottom joints to help contain the tenon to help prevent splitting. Regular is for soprano clarinets. Large is for alto and bass clarinets. Made of hard aluminum.

D6A Reverse Bench Peg \$19.50

D6B Reverse Bench Peg-Large \$19.50

SALE METRIC DIE

D210M METRIC DIE SIZE 3-.5mm \$10.00

56 LEFT!!!!

Get them while you can at this special price!!

Regular price is \$15.50

NEW Z61-16 BASE VISE



A good rod vise to mount and use in the Z61's mandrel clamp.

Z61-16 Base Vise \$53.50



Musical Patents of the Past

No. 117

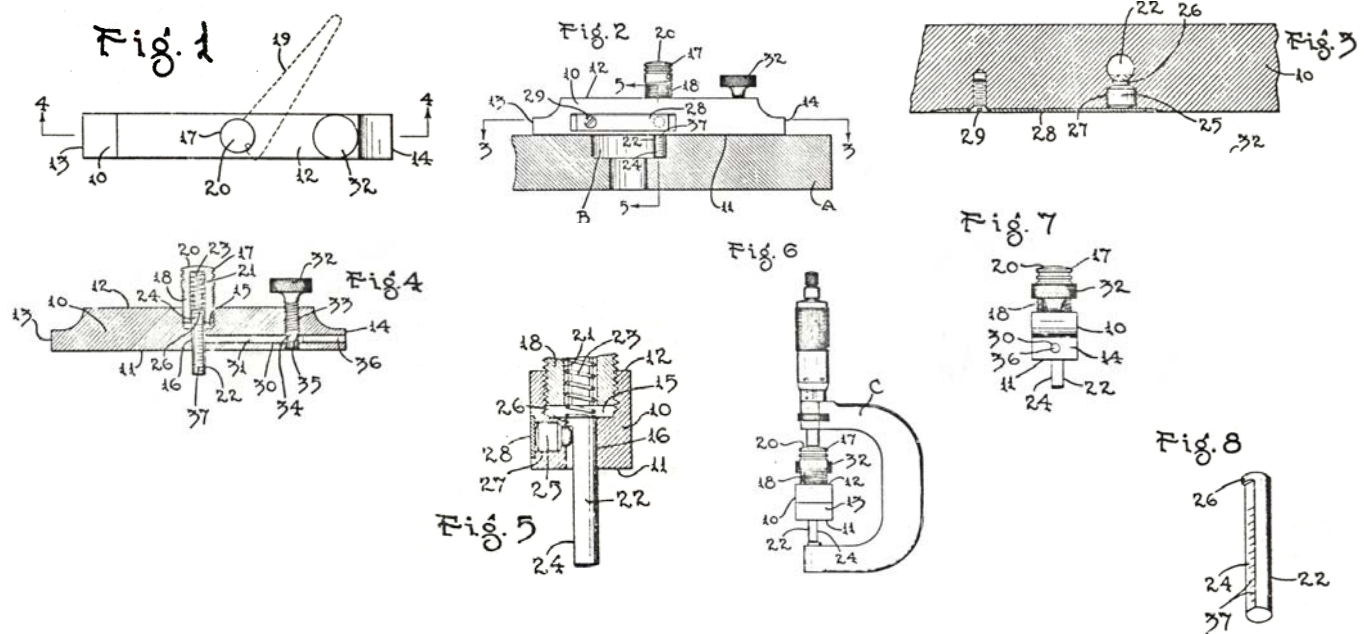

**F.J. VIERLING
GAUGE
FILED JULY 18, 1938**

Feb. 20, 1940

2,190,899

This invention relates to a gauge useful for many purposes, but more especially adapted to be employed as a depth gauge.

An object of the invention is to provide a gauge wherein will be incorporated various improved features and characteristics of construction.

And a further object is to provide a simple, durable, efficient, novel and improved depth gauge.

With the above objects in view, as well as others which will appear as the specification proceeds, the invention comprises the construction, arrangement and combination of parts as now to be fully described and as hereinafter to be specifically claimed, it being understood that the disclosure herein is merely illustrative and intended in no way in a limiting sense, changes in details of construction and arrangement of parts being permissible so long as within the spirit of the invention and the scope of the claims which follow.

In the accompanying drawing forming a part of this specification.

Fig. 1 is a plain view of a gauge made

according to the invention.

Fig. 2 is a side elevational view of the gauge of Fig. 1 shown applied to use as a depth gauge;

Fig. 3 is an enlarged fragmentary horizontal sectional view, taken on line 3—3 in Fig. 2;

Fig. 4 is a vertical central longitudinal sectional view, taken on line 4—4 in Fig. 1;

Fig. 5 is an enlarged fragmentary transverse sectional view, taken on line 5—5 in Fig. 2;

Fig. 6 is an end elevational view of the gauge as seen from the left in Figs. 1, 2 and 4, disclosing said gauge applied to use in connection with a vernier caliper or micrometer;

Fig. 7 is an end elevational view of the gauge disclosing the end thereof opposite that shown in Fig. 6; and

Fig. 8 is a perspective view of a measuring element or rod of the gauge removed from the stock thereof.

With respect to the drawing and the numerals of reference thereon, a gauge stock is designated 10. As disclosed, the stock 10 is of oblong configuration and

includes a lower machined surface 11. The upper surface 12 of said stock is for convenience parallel with the lower machined surface 11 thereof. Opposite end surfaces of the stock include portions 13 and 14 thereof which are parallel with each other and are perpendicular to the lower machined surface 11 and the upper surface 12.

Said stock 10 includes a cylindrical, internally threaded opening or chamber 15 therein extending downwardly from the upper surface 12 of the stock. As shown, the opening or chamber 15 is disposed at the longitudinal and transverse center of the upper surface 12, extends in perpendicular relation to the lower machine surface 11, and terminates at about the mid-thickness of the stock. A guide channel or way 16 constitutes a continuation of the opening or chamber 15 extending from the center of the base or said opening or chamber.